

ASTEL

CCTV



TPS 24

POWER SUPPLY UNIT

CONTENTS

Safety precautions.....	2
Preface	3
Features.....	3
Precautions.....	3
Controls and connectors.....	4
Connections.....	5
Specifications.....	5

SAFETY PRECAUTIONS

In order to prevent any fatal accidents caused by misoperation or mishandling of the video switcher, be fully aware of all the following precautions.

WARNING:
THIS APPARATUS MUST BE EARTHED

WARNING:
 To prevent fire or shock hazard, do not expose this appliance to rain or moisture.

This unit is produced to comply with Directives 93/68/EEC (IEC Publ.65) and 89/336/EEC.

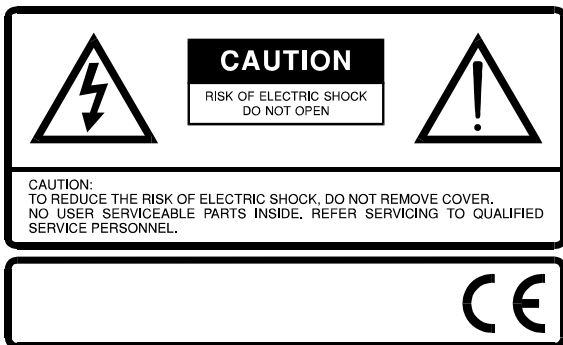

The lightning flash with arrowhead symbol, within an equilateral triangle, is intended to alert the user to the presence of uninsulated "dangerous voltage" within the product's enclosure that may be sufficient magnitude to constitute a risk of electric shock to persons.



The exclamation point within an equilateral triangle is intended to alert the user to the presence of important operating and maintenance (servicing) instruction in the literature accompanying the product.

PREFACE

The power supply unit PS24 is suitable to supply up to ten Video twisted-pair receivers TRR 101 or similar devices.

Standard 19" rack dimensions enables PS24 to be used with other rack-version CCTV switchers, amplifiers, motion detectors etc.

FEATURES

- 230V/50-60Hz input
- 24V/50-60Hz output
- 19" rack mountable

PRECAUTIONS

- Use only the power source specified on the rating label located on rear of the cabinet.
- When not using this unit for a long period of time, or when cleaning it, be sure to disconnect the power plug from the AC outlet.
- Do not drop metallic parts through slots. This action could permanently damage this unit. Do turn power off immediately and refer servicing to qualified service personnel.
- Avoid using this unit under the following conditions:
 - in extremely hot, cold or humid places,
 - in dusty places,
 - near appliances generating strong magnetic fields,
 - in places subject to direct sunlight, and
 - in badly ventilated places.
- Unplug this unit from the AC outlet and refer servicing to qualified service personnel under the following conditions:
 - when the power cord is frayed or plug is damaged
 - If the unit does not operate normally following the operating instructions
 - if the unit has been dropped or the cabinet has been damaged
 - when the unit exhibits a distinct change in performance.

CONTROLS AND CONNECTORS

FRONT PANEL

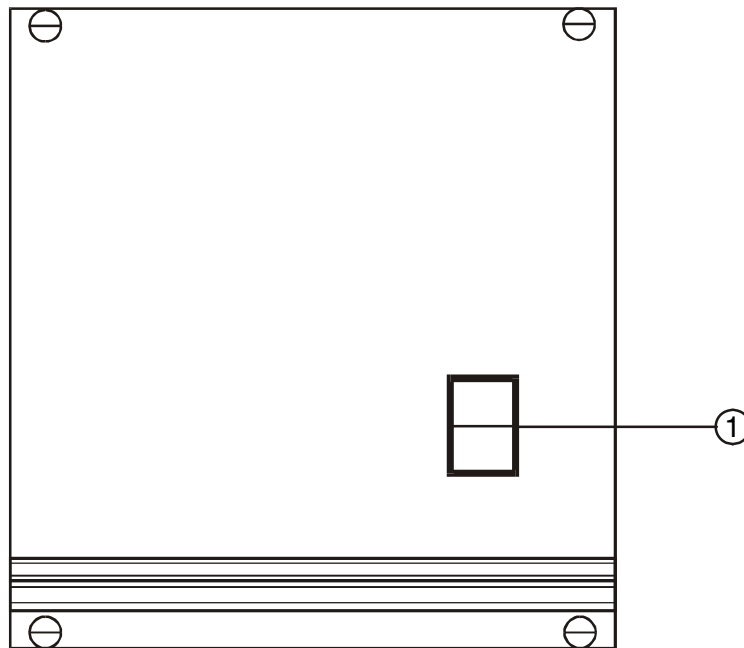

REAR PANEL

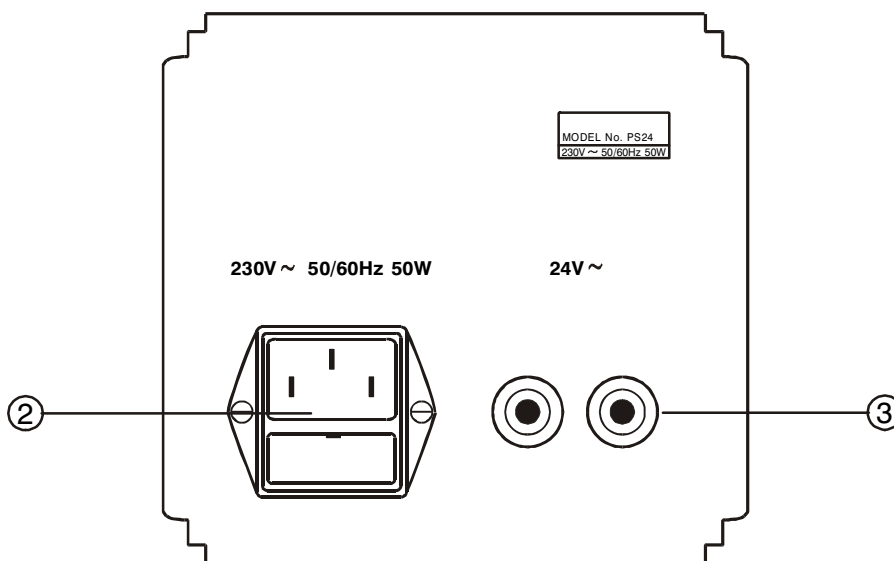

- (1) Power switch.
- (2) Power/fuse socket.
- (3) 24V AC output connector

CONNECTIONS

- Be sure to disconnect the power plug from the AC outlet before connecting to other equipment.
- Also refer to the instruction manual of the equipment to be connected.

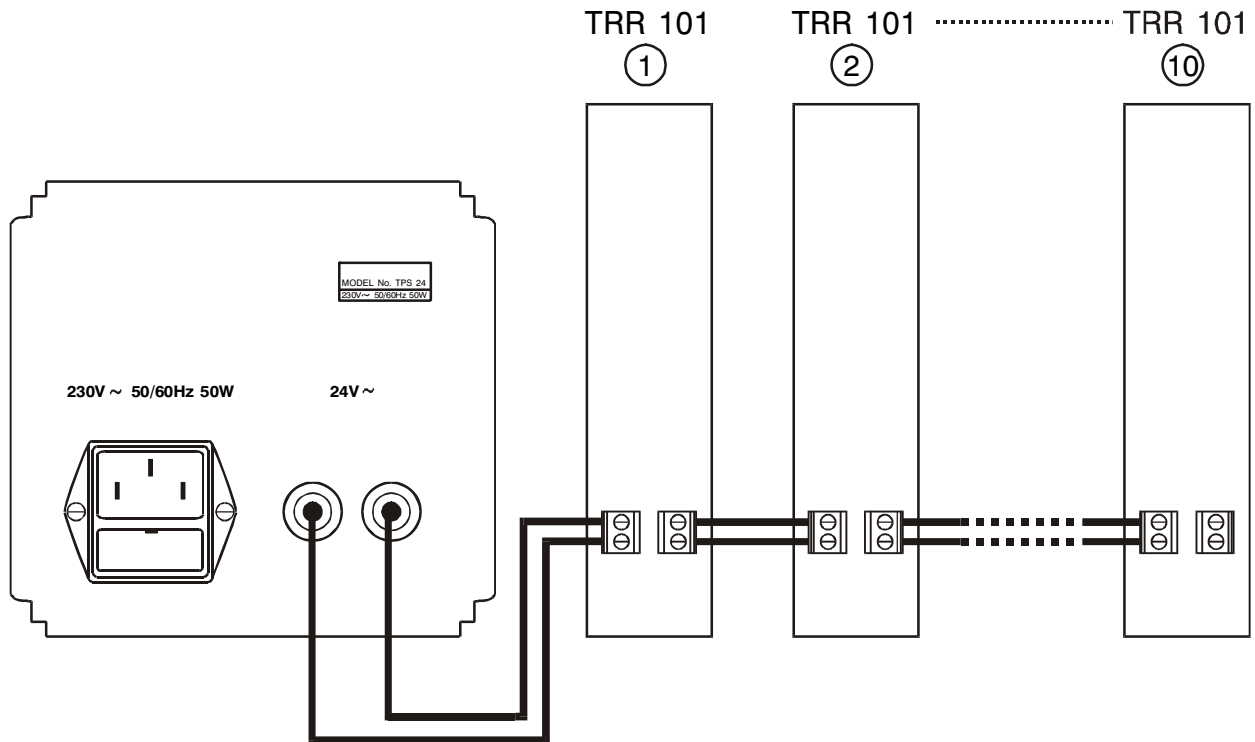

SPECIFICATIONS

Power supply output	24V, 50-60Hz
Power requirement	230V, 50-60Hz
Power consumption	50W max.
Casing	19", 3U/24TE
Weight	2.4 kg

ASTEL d.o.o., Dutovlje 138, 6221 Dutovlje, Slovenia

Tel: +386 5 7310771, +386 5 7310772

Fax: +386 5 7310789

E-mail: sales@astel-cctv.com

Web: www.astel-cctv.com