

ASTEL

CCTV



TR 1616LP

VIDEO TWISTED-PAIR RECEIVER

OPERATING INSTRUCTIONS v1.0

CONTENTS

Preface	3
Features	3
Block diagram	3
Principle of operation	3
Controls and connectors	4
Connections	5
Installation	6
Appearance	8
Specifications	8

SAFETY PRECAUTIONS

In order to prevent any fatal accidents caused by misoperation or mishandling of the video twisted-pair receiver, be fully aware of all the following precautions.

**WARNING:
THIS APPARATUS MUST BE EARTHED**

This unit is produced to comply with Directives 93/68/EEC (IEC Publ.65) and 89/336/EEC.

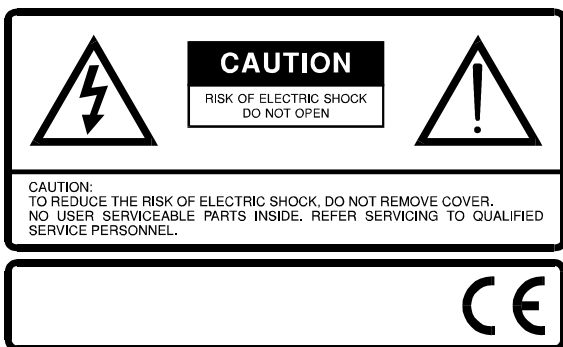

The lightning flash with arrowhead symbol, within an equilateral triangle, is intended to alert the user to the presence of uninsulated "dangerous voltage" within the product's enclosure that may be sufficient magnitude to constitute a risk of electric shock to persons.



The exclamation point within an equilateral triangle is intended to alert the user to the presence of important operating and maintenance (servicing) instruction in the literature accompanying the product.

PREFACE

The video twisted-pair receiver TR 1616LP is a sixteen-channel correction amplifier with sixteen symmetrical inputs and sixteen standard asymmetrical video outputs. Standard BNC type output connectors enables the TR 1616LP to be used with other CCTV amplifiers, switchers, cameras, monitors and digital video recorders. All adjustments are available with only three trimmers to adjust linear and high frequency gain. There are green and red LED which indicate the power-on and the video signal error in the video input of the receiver.

FEATURES

- 16 symmetrical video inputs
- 16 asymmetrical video outputs
- simple adjustments
- over-voltage protection
- rack mountable using optional rack mount kit

PRECAUTIONS

- Use only the power source specified on the rating label located on rear of the cabinet.
- When not using this unit for a long period of time, or when cleaning it, be sure to disconnect the power plug from the AC outlet.
- Do not drop metallic parts through slots. This action could permanently damage this unit. Do turn power off immediately and refer servicing to qualified service personnel.
- Avoid using this unit under the following conditions:
 - in extremely hot, cold or humid places,
 - in dusty places,
 - near appliances generating strong magnetic fields,
 - in places subject to direct sunlight, and
 - in badly ventilated places.
- Unplug this unit from the AC outlet and refer servicing to qualified service personnel under the following conditions:
 - when the power cord is frayed or plug is damaged
 - if the unit does not operate normally following the operating instructions
 - if the unit has been dropped or the cabinet has been damaged
 - when the unit exhibits a distinct change in performance.

CONTROLS AND CONNECTORS

FRONT PANEL

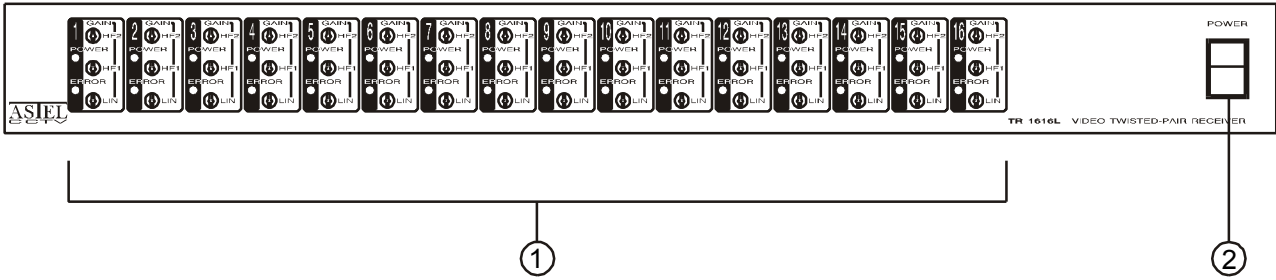

(1) CHANNELS 1 - 16

Trimmers and LEDs for adjustments and indications.

HF2 – the second high-frequency gain adjustment trimmer.

HF1 – the first high-frequency gain adjustment trimmer.

LIN – the linear gain adjustment trimmer.

POWER LED – the green LED as power-on indicator.

ERROR LED – the red LED for video signal error indication.

(2) POWER

Switch to turn the power on / off - lights in the power on position.

REAR PANEL

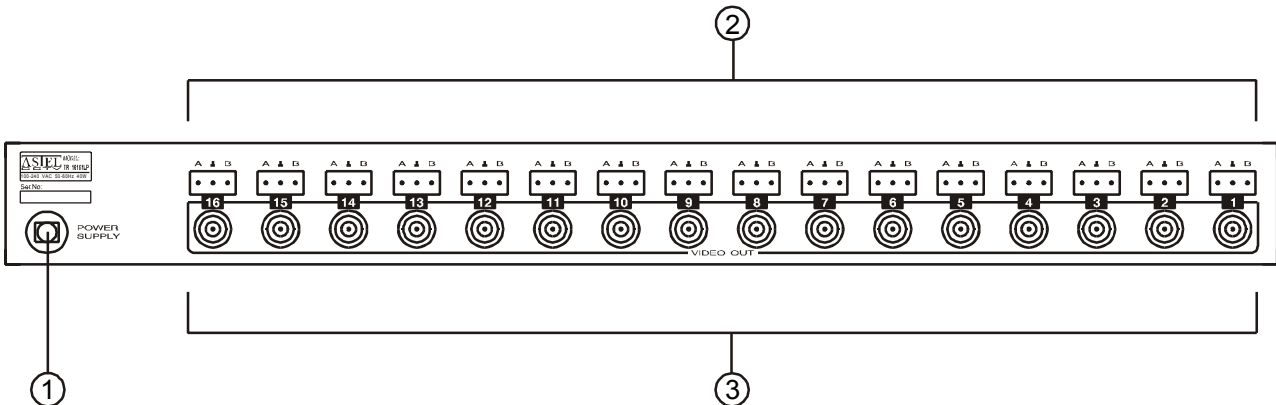

(1) POWER SUPPLY

Power cord.

(2) VIDEO INPUTS 1-16

Sixteen video input terminal block connectors to connect twisted-pair cables.

(3) VIDEO OUTPUTS 1-16

Sixteen standard BNC video output connectors.

CONNECTIONS

- Be sure to disconnect the power plug from the AC outlet before connecting to other equipment.
- Also refer to the instruction manual of the equipment to be connected.

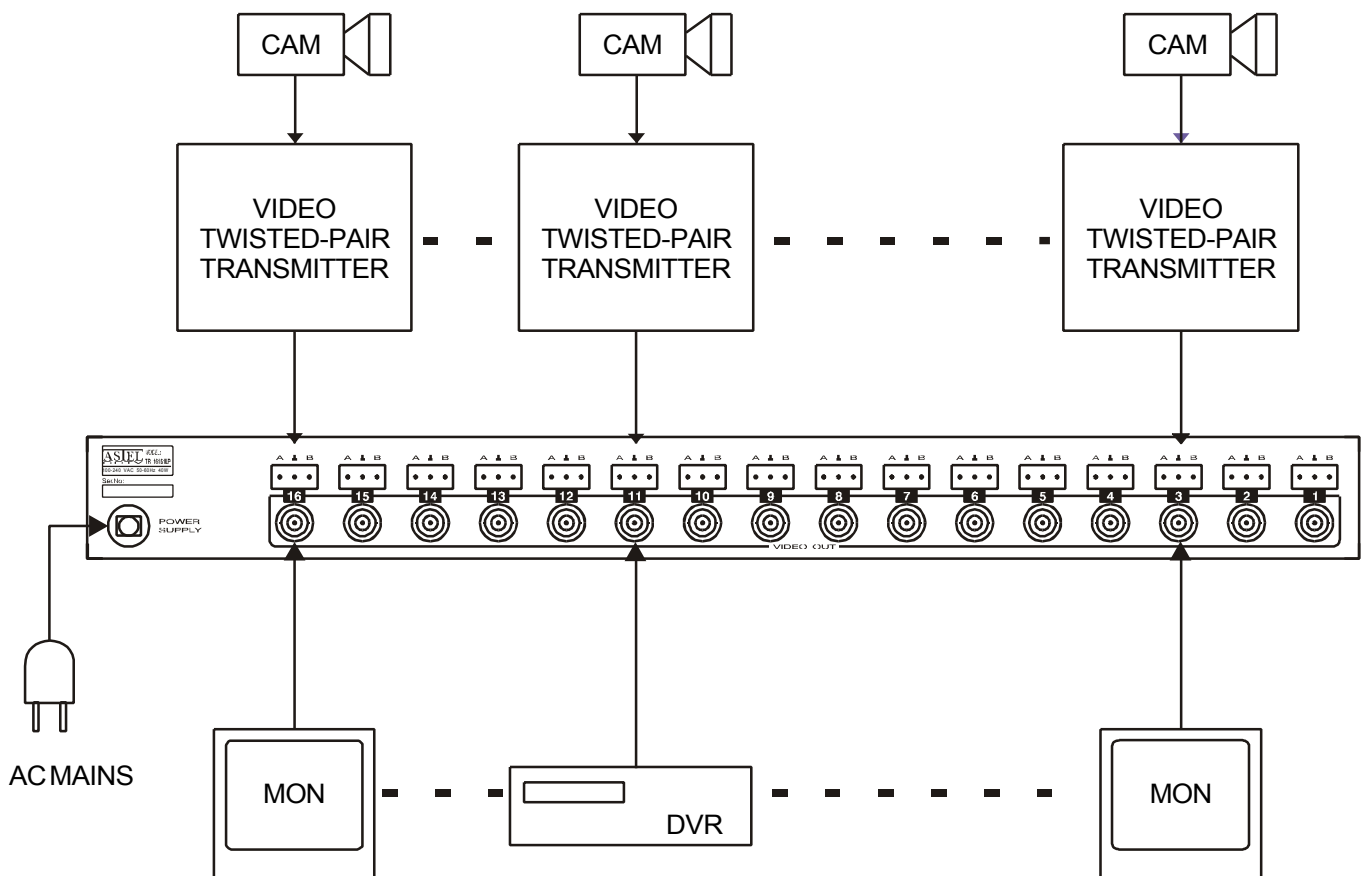

INSTALLATION

The unit is suitable to use CAT 5 or other UTP (Unshielded Twisted Pair) cables, where is possible to connect one or more units and enable to pass more than one video signal through the same cable.

- (1) Connect the power plug.
- (2) Connect the video monitor to the BNC video output connector.
- (3) Connect the twisted-pair cable to the video input terminal block connector.
- (4) Switch-on the unit.

POWER LED (green) lights, power supply is switched-on.

If there is a video signal at the input, **ERROR** LED (red) doesn't light.

- (5) Switch-on the video monitor.
- (6) Set the correct output video signal (1 Vpp) - trimmer **LIN**.
- (7) Do the adjustment of high frequencies with trimmer **HF1**.
- (8) Do the fine adjustment of high frequencies with trimmer **HF2**.
- (9) Correct the output video signal (1 Vpp) - trimmer **LIN**.
- (10) If there is too much noise in the signal, set the pre-emphasis to **+10 dB** in the video twisted-pair transmitter and repeat the adjustments from step (6) to (9).

Maximum distances (CAT 5 UTP Cable) between different models of video twisted-pair transmitters and receivers:

Model	TT 101	TT 101S	TTP 101	TTR 101	TTR 202	TTM 101	TTM 101C
TR 101	1600	1600	1800	1600	1600	1800	1800
TR 101L	1500	1500	1500	1500	1500	1500	1500
TR 101LS	1500	1500	1500	1500	1500	1500	1500
TRP 101	1600	1600	1800	1600	1600	1800	1800
TRP 101L	1500	1500	1500	1500	1500	1500	1500
TR 404L	1500	1500	1500	1500	1500	1500	1500
TR 404LP	1500	1500	1500	1500	1500	1500	1500
TR 808L	1500	1500	1500	1500	1500	1500	1500
TR 808LP	1500	1500	1500	1500	1500	1500	1500
TR 1616L	1500	1500	1500	1500	1500	1500	1500
TR 1616LP	1500	1500	1500	1500	1500	1500	1500
TRR 101	1600	1600	1800	1600	1600	1800	1800
TRR 101L	1500	1500	1500	1500	1500	1500	1500
TRR 202L	1500	1500	1500	1500	1500	1500	1500
TRM 101	850	850	900	850	850	900	900
TRM 101C	850	850	900	850	850	900	900

Model	TT 404	TT 404P	TT 808	TT 808P	TT 1616	TT 1616P
TR 101	1600	1600	1600	1600	1600	1600
TR 101L	1500	1500	1500	1500	1500	1500
TR 101LS	1500	1500	1500	1500	1500	1500
TRP 101	1600	1600	1600	1600	1600	1600
TRP 101L	1500	1500	1500	1500	1500	1500
TR 404L	1500	1500	1500	1500	1500	1500
TR 404LP	1500	1500	1500	1500	1500	1500
TR 808L	1500	1500	1500	1500	1500	1500
TR 808LP	1500	1500	1500	1500	1500	1500
TR 1616L	1500	1500	1500	1500	1500	1500
TR 1616LP	1500	1500	1500	1500	1500	1500
TRR 101	1600	1600	1600	1600	1600	1600
TRR 101L	1500	1500	1500	1500	1500	1500
TRR 202L	1500	1500	1500	1500	1500	1500
TRM 101	850	850	850	850	850	850
TRM 101C	850	850	850	850	850	850

The maximum distance can also be increased by using the cable with lower cable attenuation – like PE cable (A-2Y (L) 2Y)

SPECIFICATIONS

Video input	:	16, 0.12 - 2Vpp, terminal block
Video output	:	16, 1Vpp, 75 Ω, BNC
Input impedance	:	120 Ω
Freq. response	:	50 Hz - 5 MHz (-3 dB)
Linear gain adjustment	:	-3 dB - +20 dB (LIN)
HF1 gain adjustment	:	max. +24 dB (HF1)
HF2 gain adjustment	:	max. +20 dB (HF2)
Input protection	:	noble-gas filled surge arrester, zener diodes
Indicators	:	LED green - power-on LED red - video-signal-error
Power requirement	:	100-240VAC, 50-60Hz
Power consumption	:	40W max.
Dimensions	:	216(W) x 44(H) x 240(D) mm
Weight	:	2.0 kg

ASTEL d.o.o., Dutovlje 138, 6221 Dutovlje, Slovenia
Tel: +386 5 7310771, +386 5 7310772
Fax: +386 5 7310789
E-mail: sales@astel-cctv.com
Web: www.astel-cctv.com