

ASTEL

CCTV

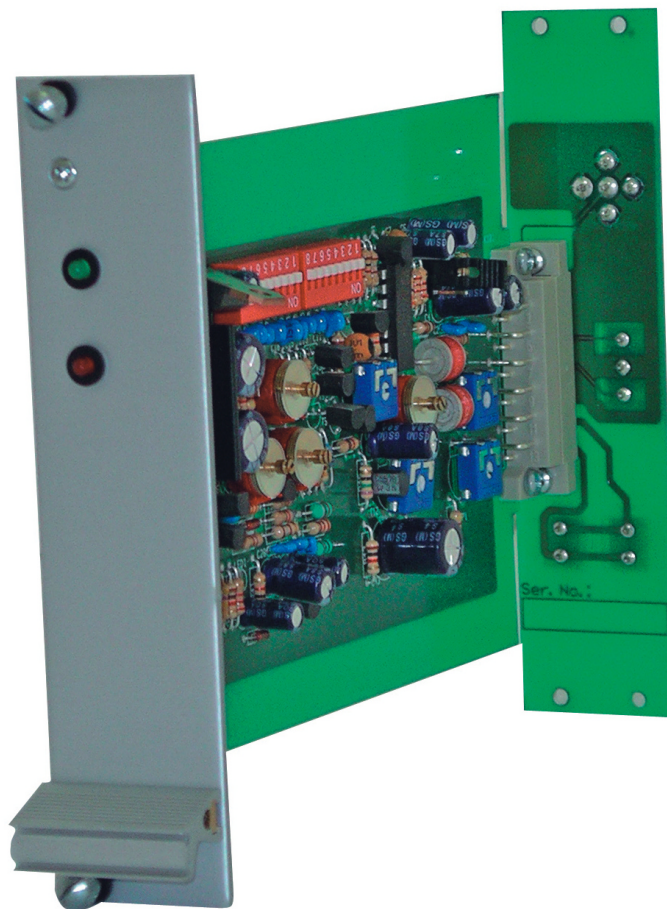

TRR 101

VIDEO TWISTED-PAIR RECEIVER

CONTENTS

Preface	3
Features	3
Block diagram.....	3
Principle of operation.....	3
Controls and connectors	4
Connections	5
Installation	6
Appearance	8
Specifications	8



This unit is produced to comply with Directive 89/336/EEC.

PREFACE

The video twisted-pair receiver TRR 101 is a correction amplifier with a symmetrical input and the standard asymmetrical video output. It is suitable to fit in a 19" standard rack 3U. The numerous trimmers help to adjust the input

impedance, symmetry, linear gain and rough or fine gain adjustment at different frequencies. There are LED1 and LED2 which indicate the power-on and the video signal error in the video input of the receiver.

FEATURES

- 19"/3U rack mountable
- small dimensions 3U/6TE
- AC/DC power supply
- low power consumption
- over-voltage protection
- max. +60 dB gain at 5 MHz

BLOCK DIAGRAM

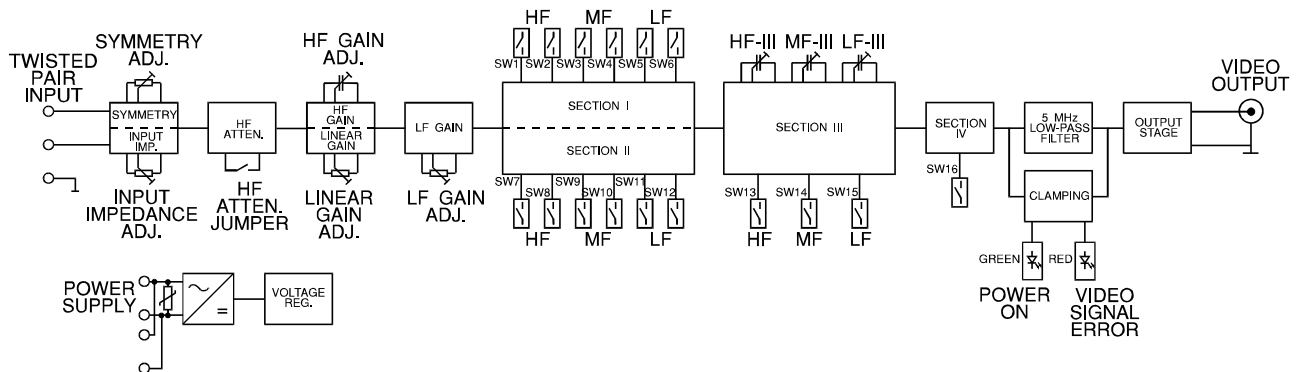

PRINCIPLE OF OPERATION

The input stage enables the setting of the input impedance and symmetry.

The minimal high frequency gain is 6 dB and the high frequency attenuation should be switched-on at short distances.

The next two stages enable the linear gain adjustment and the square-wave response adjustment. There follow the filter stages with sixteen switches and their adequate elements for the fine adjustment with total gain from +6 to +60 dB.

In the end there are the low-pass filter and the clamping circuit with the indication of power-on (the green LED) and the video-signal-error indication (the red LED).

With the help of the output stage the standard video output with the impedance of 75 ohm is achieved.

The power is supplied by connecting to the AC or DC power supply unit.

CONTROLS AND CONNECTORS

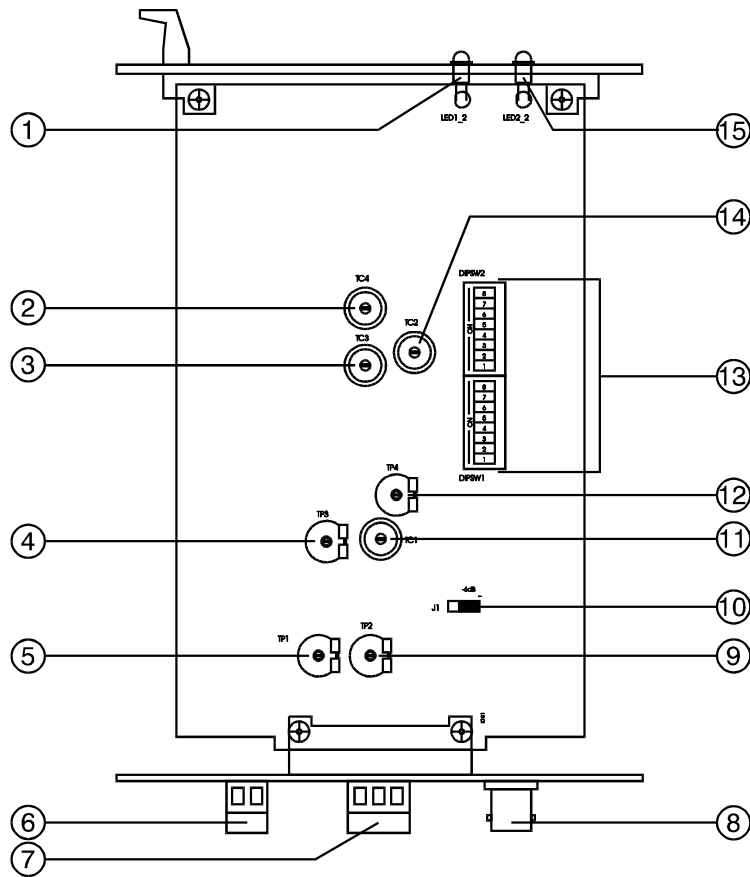

(1) LED 1
Red LED for video signal error indicator.

(2) TC 4
LF-III fine adjustment trimmer.

(3) TC 3
MF-III fine adjustment trimmer.

(4) TP 3
Linear gain adjustment trimmer.

(5) TP 1
Input impedance adjustment trimmer.

(6) AC/DC POWER SUPPLY
Power supply terminal block connector.

(7) TWISTED-PAIR INPUT
Twisted-pair terminal block connector.

(8) VIDEO OUTPUT
Video output terminal block connector.

(9) TP 2
Symmetry adjustment trimmer.

(10) J 1
HF attenuation (short distance) jumper.

(11) TC 1
HF gain adjustment trimmer.

(12) TP 4
LF gain adjustment trimmer.

(13) SW1-SW16
LF/MF/HF gain switches.

DIPSW2

8	SW16 - HF-V
7	SW15 - LF-III
6	SW14 - MF-III
5	SW13 - HF-III
4	SW12 - LF-II
3	SW11 - LF-II
2	SW10 - MF-II
1	SW 9 - MF-II

8	SW 8 - HF-II
7	SW 7 - HF-II
6	SW 6 - LF-I
5	SW 5 - LF-I
4	SW 4 - MF-I
3	SW 3 - MF-I
2	SW 2 - HF-I
1	SW 1 - HF-I

DIPSW1

(14) TC 2
HF-III fine adjustment trimmer.

(15) LED 2
Green LED as power-on indicator.

CONNECTIONS

- Be sure to switch-off the power supply unit before connecting to other equipment.
- Also refer to the instruction manual of the equipment to be connected.

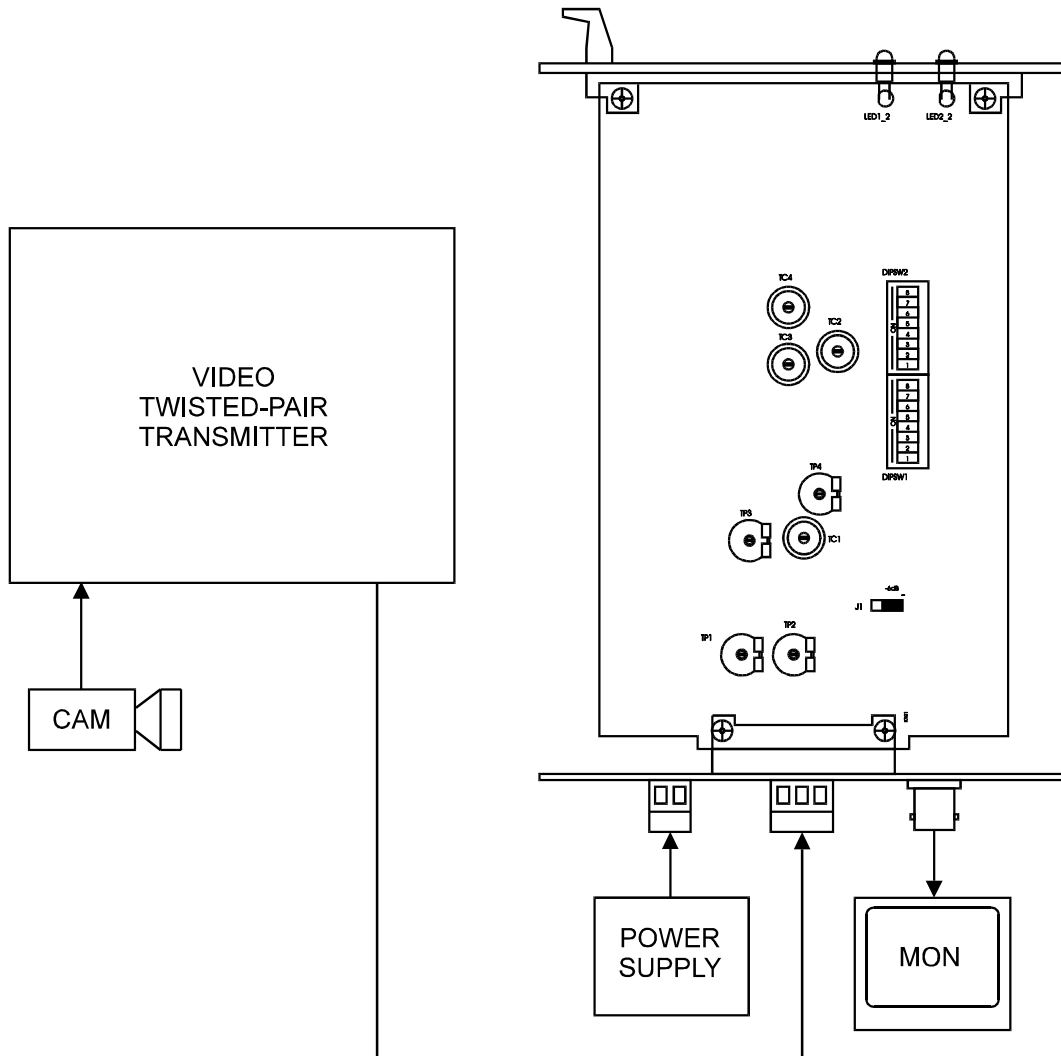

INSTALLATION

- (1) Set the trimmer **TP2** to the middle position.
- (2) Set the trimmer **TP3** to the middle position.
- (3) Set the trimmer **TP4** to the left.
- (4) Switch-off **SW1-SW15**, **SW16** switch-on.
- (5) Set **TC1**, **TC2**, **TC3** and **TC4** to the minimal capacitance.
- (6) In the **Table 1** select the **CABLE** (insulation, impedance Z_L , loss $a_{5\text{MHz}}/\text{km}$) and calculate the cable loss $a_{5\text{MHz}}$. (see **Example 1** and **Example 2**)
- (7) Set the trimmer **TP1** - measure with ohm-meter between **A** and **B**.
Adjust resistance between **A** and **B** to achieve cable impedance Z_L . ($R_{AB} = Z_L$)
- (8) Switch-on the adequate switches (**Table 1**) to compensate the cable loss $a_{5\text{MHz}}$.
In the **SECTION I** or **SECTION II** only one group of switches (**10dB** or **20dB**) can be switched-on in the same time. (see **Example 1** and **Example 2**)
- (9) Connect the power supply unit (AC or DC) to the **K1**.
- (10) Connect the video monitor to the video output **K2**.
- (11) Connect the twisted-pair cable to the **K3**.
- (12) Switch-on the power supply units.
LED2 (green) lights, power supply is switched-on.
If there is a video signal at the input, **LED1** (red) doesn't light.
- (13) Switch-on the video monitor.
- (14) Check the positive video input signal between **A** and \wedge .
- (15) Check the negative video input signal between **B** and \wedge .
- (16) Set the output video signal to 1 Vpp - trimmer **TP3**.
- (17) Do the fine adjustment with **TC2**, **TC3**, **TC4**, correct the sync. pulse with **TP4**, **TC1**. (**Fig. 1**)
- (18) If adjustment with **TC2**, **TC3**, **TC4** is not possible, switch-on **SW13**, **SW14**, **SW15** and do the fine adjustment.
- (19) Set the minimal disturbance - trimmer **TP2**.
- (20) Correct the output video signal to 1 Vpp - trimmer **TP3**.
- (21) If there is too much noise in the signal (gain adj. > 50 dB at 5 MHz), set the pre-emphasis to **+10 dB** in the video twisted-pair transmitter.
- (22) If $a < 6$ dB (short distance), **SW1-SW15** switch-off, **SW16** switch-on, jumper **J1** set to **-6 dB** and do the fine adjustment.

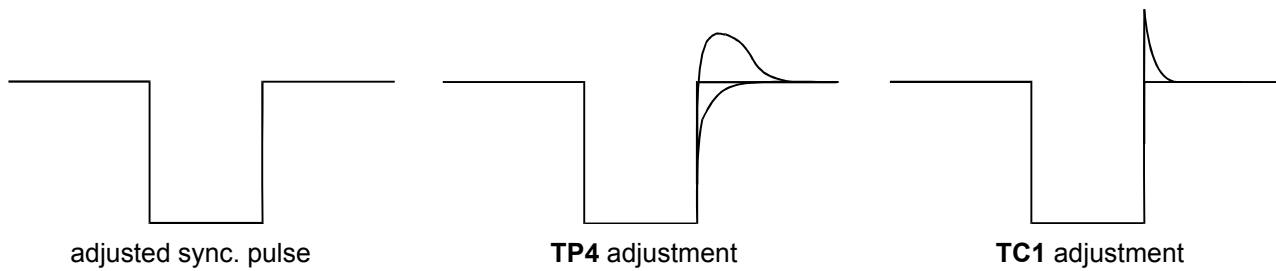

Fig. 1: Sync. pulse correction

Table 1

CABLE				SECTION I (SW1-SW6)		SECTION II (SW7-SW12)	
TYPE	INSULATION	Z_L/W	$a_{5\text{MHz/km}}$	10 dB	20 dB	10 dB	20 dB
P	paper	150	51 dB	2 4	1 2 6	8 10	7 8 12
P	paper	125	35 dB	2 4 6	1 2 5	8 10 12	7 8 11
P	paper	125	33 dB	2 4 6	1 2 4 5	8 10 12	7 8 10 11
P	paper	125	30 dB	2 4 6	1 2 4 5	8 10 12	7 8 10 11
Y	PVC	90	65 dB	2 4 6	1 2 4 5	8 10 12	7 8 10 11
Y	PVC	100	40 dB	2 4 6	1 2 3 5	8 10 12	7 8 9 11
2Y,2YF	PE	130	40 dB	2 4 6	1 2 5	8 10 12	7 8 11
2Y,2YF,02Y	PE	135	30 dB	2 4 6	1 2 4 5	8 10 12	7 8 10 11
2Y,2YF,02Y	PE	135	24 dB	2 4 5	1 2 3 4 5 6	8 10 11	7 8 9 10 11 12
02Y	PE	140	21 dB	2 4 5	1 2 3 4 5 6	8 10 11	7 8 9 10 11 12

Example 1:

Cable specifications: $Z_L=125 \Omega$, $a_{5\text{MHz/km}}=30 \text{ dB}$, paper insulation, cable length $L=500 \text{ m}$.

(1) $a_{5\text{MHz}}=a_{5\text{MHz/km}} \times L=15 \text{ dB}$

(2) In **Table 1** find column **10 dB** in **SECTION I** or in **SECTION II**.

Switch-on the switches 2, 4 and 6 or 8, 10 and 12. (page 5)

(3) Do the fine adjustment (+5 dB) with TC1, TC2, TC3, TC4 and TP4.

Example 2:

Cable specifications: $Z_L=100 \Omega$, $a_{5\text{MHz/km}}=40 \text{ dB}$, PVC insulation, cable length $L=1000 \text{ m}$.

(1) $a_{5\text{MHz}}=a_{5\text{MHz/km}} \times L=40 \text{ dB}$

(2) In **Table 1** find column **20 dB** in **SECTION I** and in **SECTION II**.

Switch-on the switches 1, 2, 3, 5, 7, 8, 9, and 11. (page 5)

(3) Do the fine adjustment with TC1, TC2, TC3, TC4 and TP4.

Note:

- It is not necessary to keep the instructions in **Table 1** strictly in the practical use.

APPEARANCE

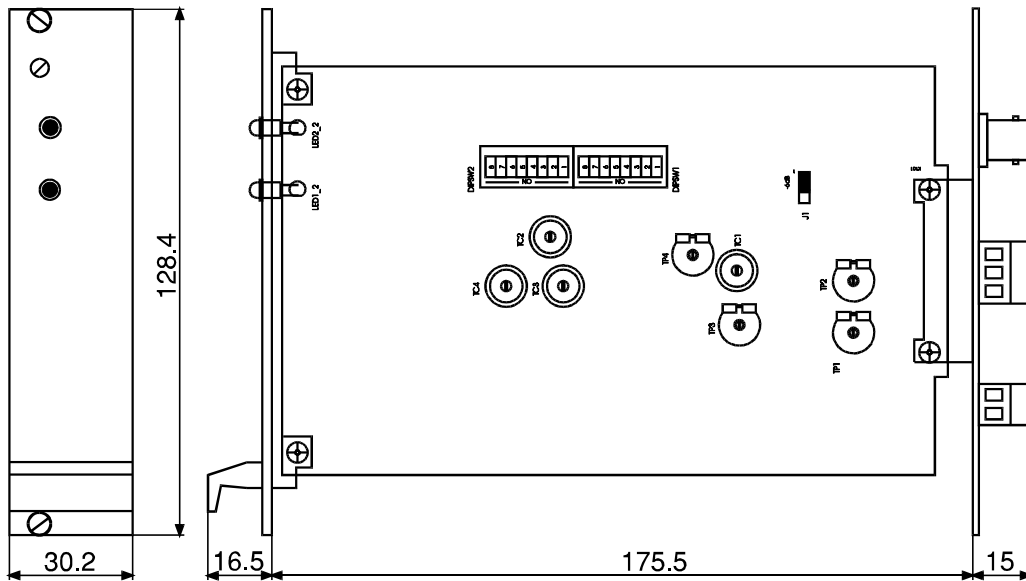

SPECIFICATIONS

Video input	:	0.12 - 2 Vpp (TP3)
Input impedance	:	45 Ω - 175 Ω (TP1)
Video output	:	1 Vpp, 75 Ω
Freq. response	:	50 Hz - 5 MHz (-3 dB)
Disturbance reduction	:	> 70 dB, 50 Hz (TP2)
Gain adjustment	:	+6 dB...+60 dB at 5 MHz (SW1-SW16, TC, TP)
Noise	:	-50 dB at +40 dB gain adj. -47 dB at +60 dB gain adj.
Power supply	:	24 V, AC/DC, 100 mA max.
Input protection	:	noble-gas filled surge arrester, zener diodes
Power supply protection	:	varistor
Indicators	:	LED2 (green) - power-on LED1 (red) - video-signal-error
Casing	:	3U/6TE card panel
Dimensions (incl. partial mother board)	:	30.2(W) x 128.4(H) x 207(D) mm

ASTEL d.o.o., Dutovlje 138, 6221 Dutovlje, Slovenia
Tel: +386 5 7310771, +386 5 7310772
Fax: +386 5 7310789
E-mail: sales@astel-cctv.com
Web: www.astel-cctv.com