

# ASTEL

## CCTV



# TS 081

## VIDEO AUTO SWITCHER

---

OPERATING INSTRUCTIONS v2.0

# CONTENTS

Safety precautions .....	2
Preface.....	3
Features.....	3
Precautions .....	3
Controls and connectors .....	4
Connections .....	5
Specifications.....	5

## SAFETY PRECAUTIONS

In order to prevent any fatal accidents caused by misoperation or mishandling of the video switcher, be fully aware of all the following precautions.

**WARNING:  
THIS APPARATUS MUST BE EARTHED**

**WARNING:**  
To prevent fire or shock hazard, do not expose this appliance to rain or moisture.

This unit is produced to comply with Directives 93/68/EEC (IEC Publ.65) and 89/336/EEC.

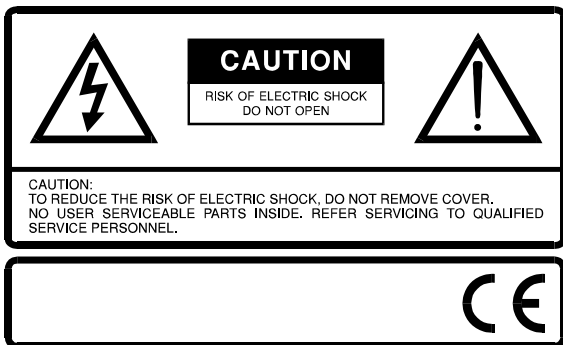

The lightning flash with arrowhead symbol, within an equilateral triangle, is intended to alert the user to the presence of uninsulated "dangerous voltage" within the product's enclosure that may be sufficient magnitude to constitute a risk of electric shock to persons.



The exclamation point within an equilateral triangle is intended to alert the user to the presence of important operating and maintenance (servicing) instruction in the literature accompanying the product.

## PREFACE

The TS 081 is a video switcher which is suitable to connect up to eight cameras or other video sources.

The sophisticated built-in electronic circuit allows smooth switchings without picture roll or flutter

Standard BNC type input and output connectors enables TS 081 to be used with other CCTV switchers, cameras, monitors and video tape recorders.

## FEATURES

- 8 video inputs
- 1 video output
- vertical interval switching
- rack mountable using optional rack mount kit

## PRECAUTIONS

- Use only the power source specified on the rating label located on rear of the cabinet.
- When not using this unit for a long period of time, or when cleaning it, be sure to disconnect the power plug from the AC outlet.
- Do not drop metallic parts through slots. This action could permanently damage this unit. Do turn power off immediately and refer servicing to qualified service personnel.
- Avoid using this unit under the following conditions:
  - in extremely hot, cold or humid places,
  - in dusty places,
  - near appliances generating strong magnetic fields,
  - in places subject to direct sunlight, and
  - in badly ventilated places.
- Unplug this unit from the AC outlet and refer servicing to qualified service personnel under the following conditions:
  - when the power cord is frayed or plug is damaged
  - If the unit does not operate normally following the operating instructions
  - if the unit has been dropped or the cabinet has been damaged
  - when the unit exhibits a distinct change in performance.

# CONTROLS AND CONNECTORS

## FRONT PANEL

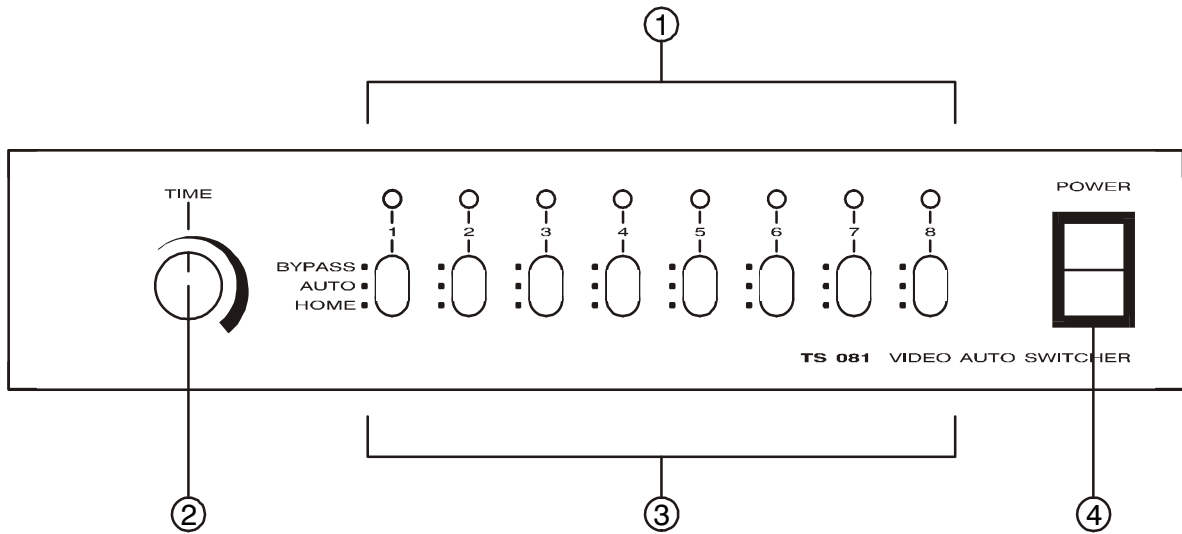

## REAR PANEL

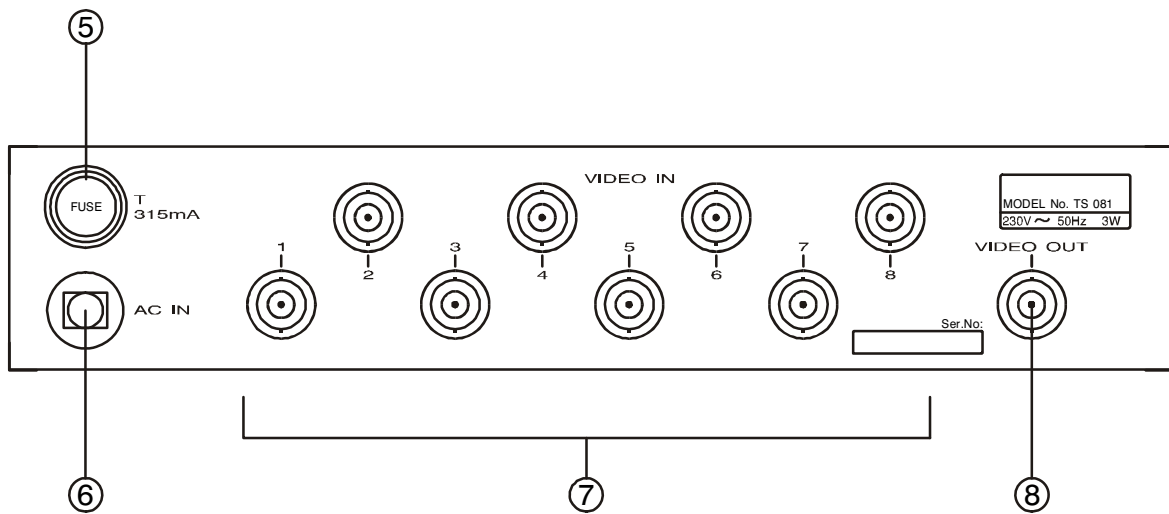

- (1) LED indicators - for each video input.
- (2) Sequential time adjustment.
- (3) By pass/auto/home selectors.
- (4) Power switch.
- (5) Fuse socket.

- (6) Power cord.
- (7) Video input connectors.
- (8) Video output connector.

## CONNECTIONS

- Be sure to disconnect the power plug from the AC outlet before connecting to other equipment.
- Also refer to the instruction manual of the equipment to be connected.

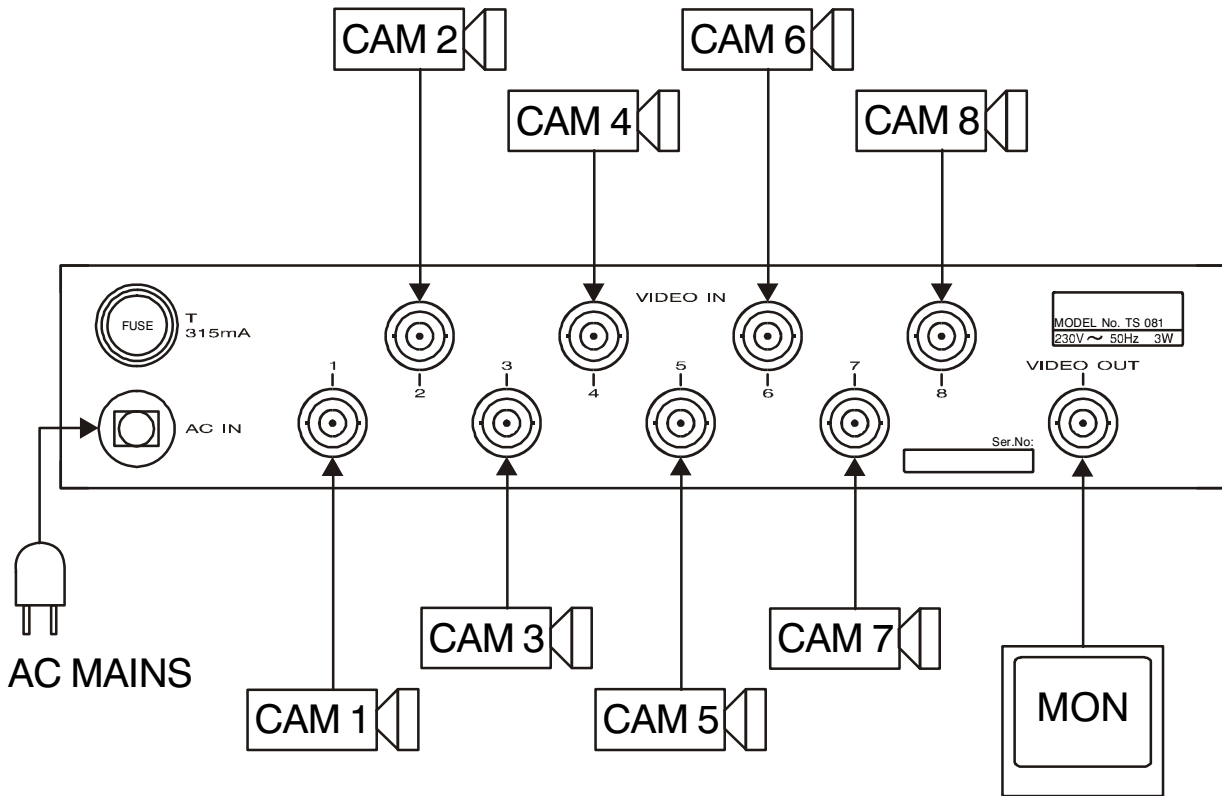

## SPECIFICATIONS

Video input	1Vpp/75Ω, BNC
Video output	1Vpp/75Ω, BNC
Video bandwidth	10MHz±3dB
Signal/noise ratio	>55dB
Crosstalk	>40dB
Switching interval	adjustable, 1-40sec.
Power requirement	230V, 50Hz
Power consumption	3W max.
Dimensions	216x44x240mm
Weight	2.2 kg





ASTEL d.o.o., Dutovlje 138, 6221 Dutovlje, Slovenia  
Tel: +386 5 7310771, +386 5 7310772  
Fax: +386 5 7310789  
E-mail: [sales@astel-cctv.com](mailto:sales@astel-cctv.com)  
Web: [www.astel-cctv.com](http://www.astel-cctv.com)